



FSL-1230PR01-08

PROFESSIONAL WOOFER

● Cost Optimized

● Fabric Surround

● Paper Diaphragm

● Optimized for Pro Applications

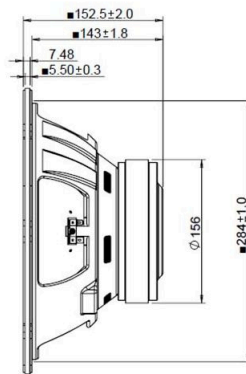
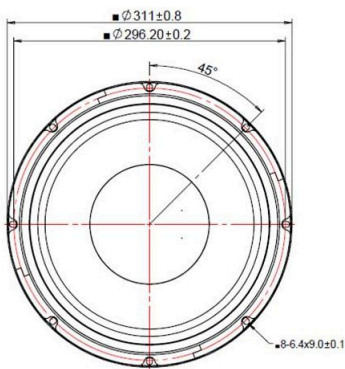

SPECIFICATIONS

Transducer Size	12	in
Impedance	8	Ω
Frequency Range ¹	30 - 2000	Hz
Sensitivity ² (2.83V 1W @ 1m)	89.8 89.8	dB
Power Rating (IEC 268-5)	600	W
Voice Coil Size	75.7	mm
Air Gap Winding Height	H _{ag} H _{vc}	8 26.8
Net Weight	5.5	kg

PARAMETERS ³

Eff. Piston Area	S _d	535	cm ²
DC Resistance	R _e	6.1	Ω
Minimum Impedance	Z _{min}	7.2	Ω
Inductance	L _e	1.52	mH
Resonance Frequency ⁴	F _s	46	Hz
Mechanical Q Factor	Q _{ms}	8.31	-
Electrical Q Factor	Q _{es}	0.801	-
Total Q Factor	Q _{ts}	0.73	-
Moving Mass	M _{ms}	83.6	g
Compliance	C _{ms}	140	μ m/N
Equivalent Volume	V _{as}	57.3	L
Motor Force Factor	Bl	13.6	Tm
Motor Efficiency	β	30.4	(Bl) ² / R _e
Linear Excursion ⁵	X _{max}	12.1	mm
Max Mechanical Excursion ⁶	X _{mech}	20.5	mm

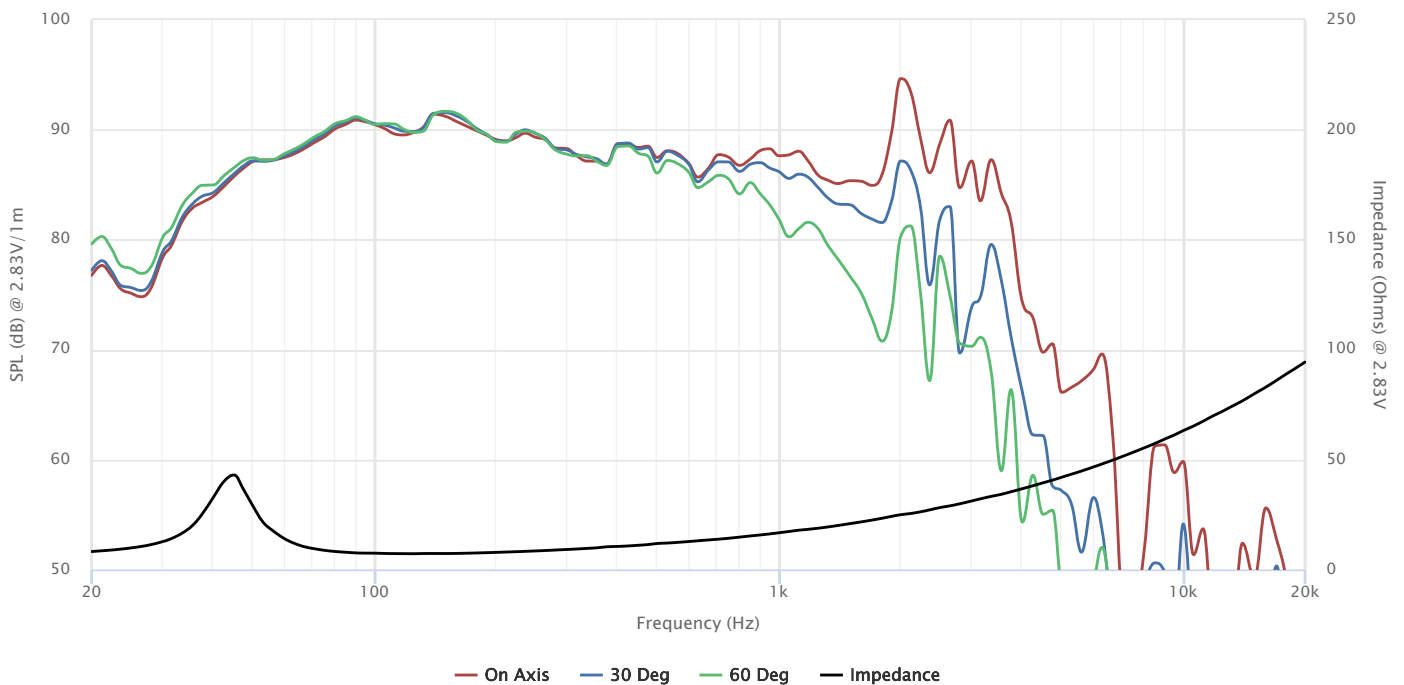

Highcharts.com

Details on this spec sheet are for reference only and should not be used for setting production limits. Specifications and product cosmetics are subject to change without notice. Peerless is a registered trademark of Tymphany Enterprises. All measurements conducted in test lab at 25°C ±10°C, 50%RH ±10%. ¹ Specified by Engineering as linear working range of transducer. ² Measured at 2.83V at 1m and normalized to 1W with respect to nominal impedance. ³ Measured in Free Air without preconditioning, therefore subject to some deviation. ⁴ Impedance and F_s value measured under different conditions. ⁵ Equal/Overhang: (H_{vc} - H_{ag})/2 + H_{ag}/3. Underhang: (H_{ag} - H_{vc})/2 + H_{vc}/3. ⁶ Mechanically limited excursion (e.g. bottoming, spider crash).